

Technical Manual  
2-001  
Issued: 5/85  
Supersedes: 10/84

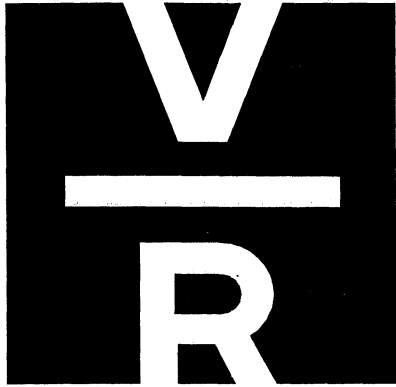

# VEEDER-ROOT

## Field Service Manual

Manual No. 231112R

Series 7269  
Electric Reset  
and

Series 7680  
Offset  
Electric Reset

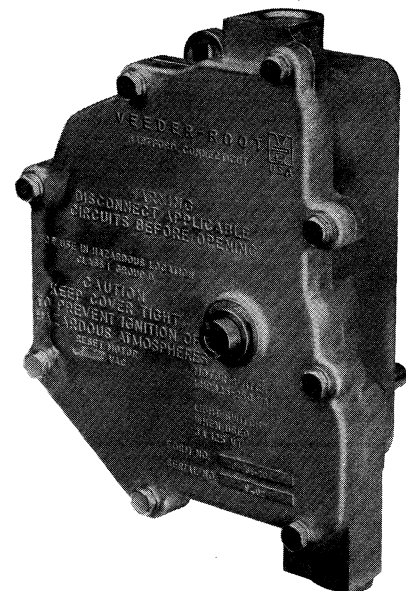
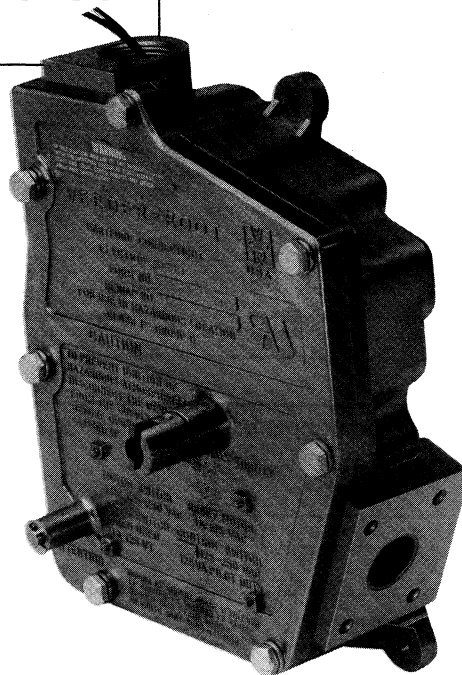



## SECTION I. INTRODUCTION

**A. GENERAL.** Every gasoline pump electric reset computer is thoroughly tested at the Veeder-Root factory and by the pump manufacturer when installed in the pump. However, like any precision built mechanism it requires periodic care to ensure service.

This manual has been compiled primarily for the manufacturer of gasoline pumps using the Veeder-Root Electric Reset Computer. With this in view it has been divided in two sections, dealing respectively with the basic operation and field service. Because the pump motor switch, light switch, and auxiliary switch are contained within the electric reset package, it is important to understand the operation of the electric reset before attempting to take corrective action. Vertical bars adjacent to text indicate information added or changed during revision date on page bottom.

For information not covered in this manual, refer to VR-101 Computer Service Manual, Form No. 231099.

Consult Veeder-Root Company on any unusual application, installation or possible modification of this basic design.

**B. WARRANTY AND CONDITIONS.** See back page.

### C. SPECIFICATIONS.

**Voltage:** 115 or 230v-ac, 50/60 Hz, as specified

**Control Switch:** 16 amp, 125 to 250v-ac, 125VA pilot duty or 24v-dc, 2 amp, as specified

**Pump Switch:** 1 hp, 125 to 250v-ac

**Light Switch:** 3 amp, 125v-ac

**Temperature Range:** -40° to +160°F

**Housing:** UL component recognition for use in Class 1, Group D applications

## SECTION II. OPERATION DESCRIPTION

### A. SERIES 7269 ELECTRIC RESET. Figure 1.

1. The 7269 is mounted directly on the computer. The input coupling to the electric reset is located on the cover and is operated by a connecting shaft to the pump handle located on the outside of the pump.

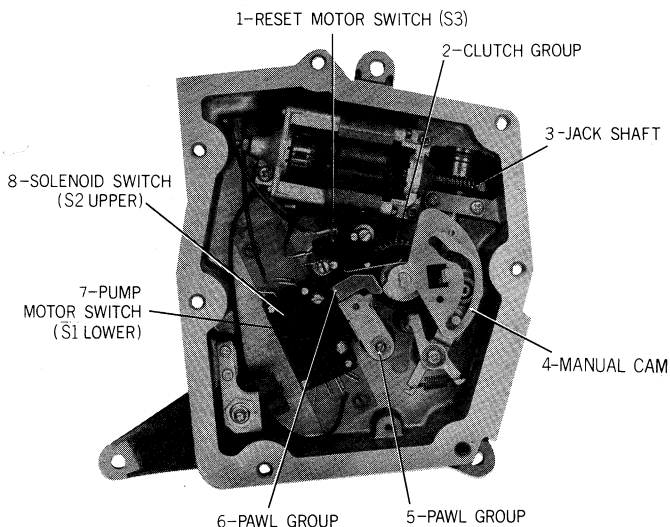

Figure 1. Series 7269 Electric Reset Parts Identification.

2. Depending upon the manufacturer of the pump, the reset may be turned on by either clockwise or counterclockwise rotation of this handle. Rotating the handle to "motor on" position closes switch, item 1, by means of cam, item 4. Closing switch, item 1, permits the reset motor to run, driving jack shaft, item 3. This power transmits thru the clutch group, item 2, and coupling to the computer, and provides the rotary motion necessary to reset the computer. These components are timed to provide an output rotation of 360 degrees.

3. During this 360 degrees, the computer shafts are shifted to the reset position, the wheels are returned to zero, and the shafts are shifted back to the "motor on" position. At this time the pump motor switch, item 7, is turned on by the switch pawl group, item 5. If additional switches are required to operate solenoid valves, interlocks, or other related devices, they too will be operated at this time.

4. Upon completion of this portion of the cycle, product delivery can be made. The pump motor is turned off by rotating the handle in the opposite direction at completion of delivery.

Note: See Parts List 231079 for placement and identification of parts.

### B. SERIES 7680 OFFSET ELECTRIC RESET. Figure 2.

1. The 7680 is mounted on the pump frame. This model reset requires a suitable exterior operating handle and simple connection to join the reset shaft to the computer. A cam and an over-center spring are incorporated in the reset housing.

2. Rotating the handle to "motor on" position closes the switch, item 1, by means of cam (not shown) and lever, item 4. Closing switch, item 1, permits the reset motor, item 6, to run, driving the gear train, item 3. This power transmits through output drive assembly, item 2, and coupling to the computer, and provides the rotary motion necessary to reset the computer. These components are timed to provide an output rotation of 360 degrees.

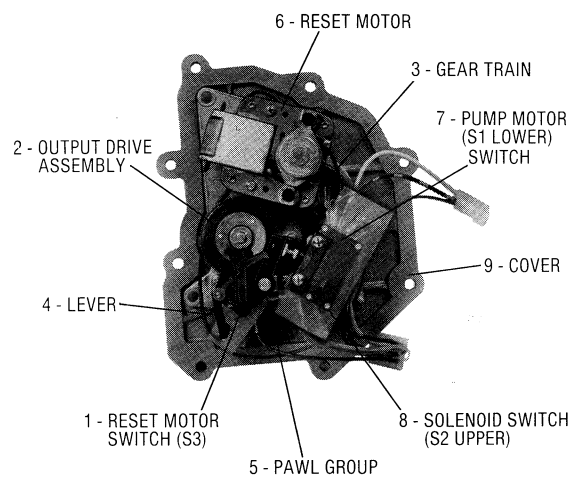

Figure 2. Series 7680 Offset Electric Reset Parts Identification.



3. During this 360 degrees, the shafts are shifted to the reset position, the wheels are returned to zero, and the shafts are shifted back to the "motor on" position. At this time the pump motor switch, item 7, is turned on by the switch pawl, item 5. If additional switches are required to operate solenoid valves, interlocks, or other related devices, they too will be operated at this time.

4. Upon completion of this portion of the cycle, product delivery can be made. The pump motor is turned off by rotating the handle in the opposite direction at completion of delivery. On the Series 7680, this rotation of the handle moves the cam (not shown) back to the starting position. The cam acts on the lever, item 4, which rotates item 2, shutting off the pump motor switch. This assures that once the pump is turned off it may not be turned on again until a full reset cycle has been accomplished.

Note: See Parts List 251146 for placement and identification.

### SECTION III. FIELD SERVICE

**WARNING: IN INSTALLATION AND USE OF THIS PRODUCT, COMPLY WITH THE NATIONAL ELECTRICAL CODE; FEDERAL, STATE, AND LOCAL CODES; AND ALL APPLICABLE SAFETY CODES. IN ADDITION, TURN OFF POWER AND TAKE OTHER NECESSARY PRECAUTIONS TO PREVENT PERSONAL INJURY, PROPERTY LOSS AND EQUIPMENT DAMAGE.**

#### A. LUBRICATION.

**WARNING: POWER MUST BE OFF WHEN WORKING ON UNIT IN THE PUMP. TO PREVENT PERSONAL INJURY, PROPERTY LOSS AND EQUIPMENT DAMAGE.**

1. Under normal conditions lubrication will be necessary only once a year.
2. Figure 3 shows the points that must be lubricated in the power package. For lubrication of the computer refer to VR-101 Computer Service Manual. Apply oil or grease to all points indicated. Use Anderol L-795 Grease and Anderol 401-D Oil.

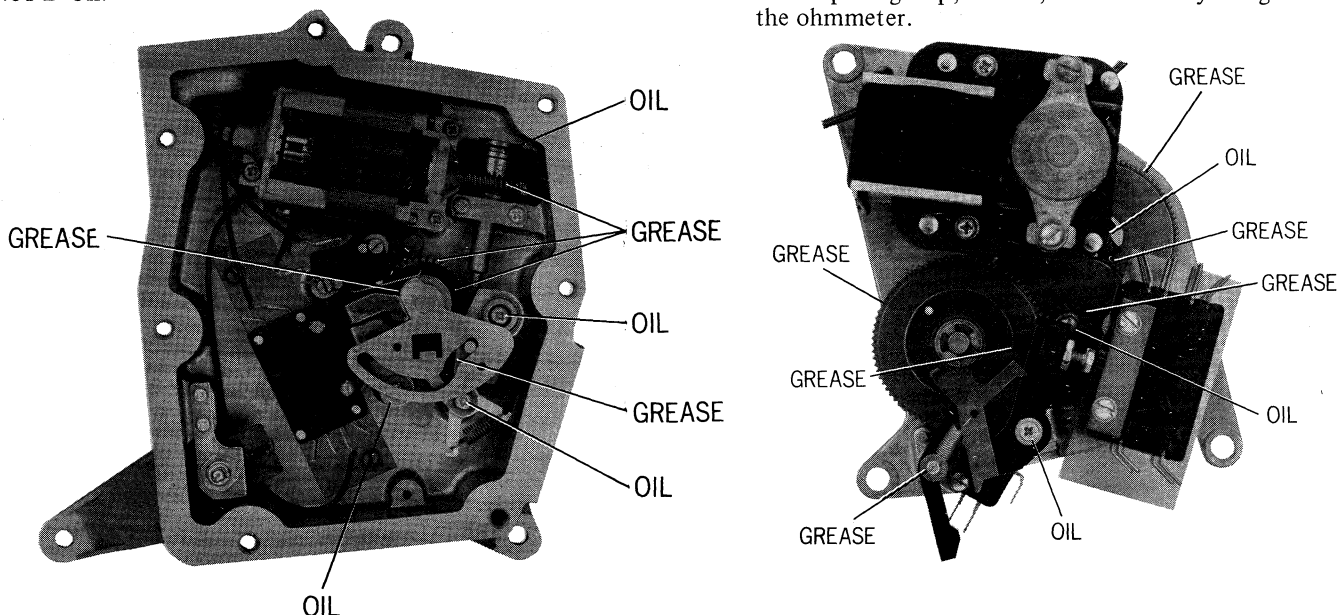

Figure 3. Series 7269 and 7680 Electric Reset Lubrication.

Revised May, 1985

**CAUTION: DO NOT LUBRICATE THE MOTOR BEARINGS. THEY ARE SELF-LUBRICATING AND OVER LUBRICATION MAY DAMAGE THE BEARINGS.**

#### B. SWITCH REPLACEMENT.

**WARNING: POWER MUST BE OFF WHEN WORKING ON THE UNIT TO PREVENT PERSONAL INJURY, PROPERTY LOSS AND EQUIPMENT DAMAGE.**

Note: When replacing switches S1 and S2, ensure that the replacement switches are of the same manufacture.

1. General. The electric reset, Figures 1, 2 and 4, contains three switches.
  - a. S1 is the pump motor control.
  - b. S2 is used as a solenoid control where this is needed.
  - c. S3 is the electric reset motor control.
2. Pump Motor Switch (S1) and Solenoid Control Switch (S2) Replacement and Adjustment for Series 7269.

In early models, S1 and S2 switches are replaced by removing two screws and exchanging the switches. In more recent models, S1 and S2 are replaced by first removing the switch mounting plate. Early style Series 7269 and current model 7627 electric resets have no adjustment for these two switches. Models of Series 7269 made after approximately March 1, 1973, do have an adjustment feature which is set as follows:

- a. Remove all power to the electric reset.
- b. Connect an ohmmeter across terminals S1-B common and S1-B N.O. or S2-B common and S2-B N.O. (if installed).
- c. Turn the clutch group, item 2, by hand until pawl group, item 5, rides upon the outside diameter of the cam.
- d. Loosen two screws on the switch adjusting plate and insert a screwdriver blade in the notch on one end of this plate.
- e. Insert a 0.020 in. feeler gage between the switch actuating button and the switch pawl group.
- f. Twist the screwdriver so the switch moves with respect to the pawl group, item 5, and continuity is registered on the ohmmeter.

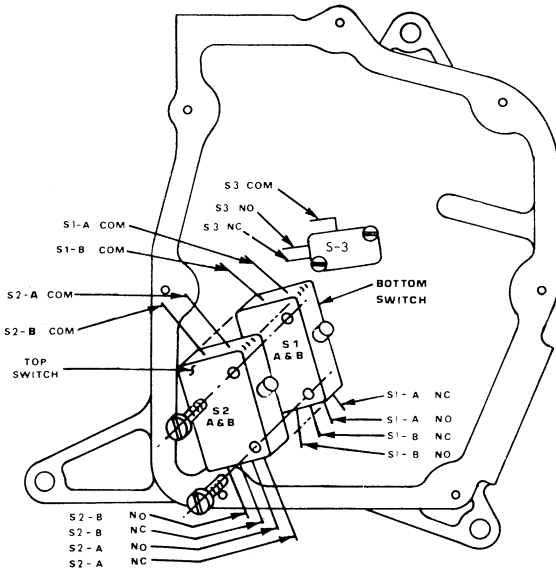

Figure 4. Electric Reset Switch Identification.

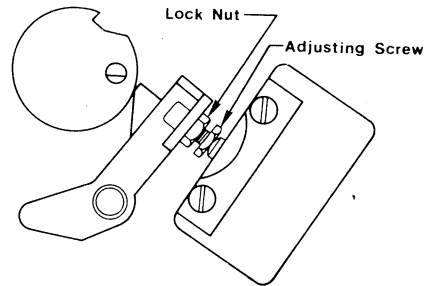
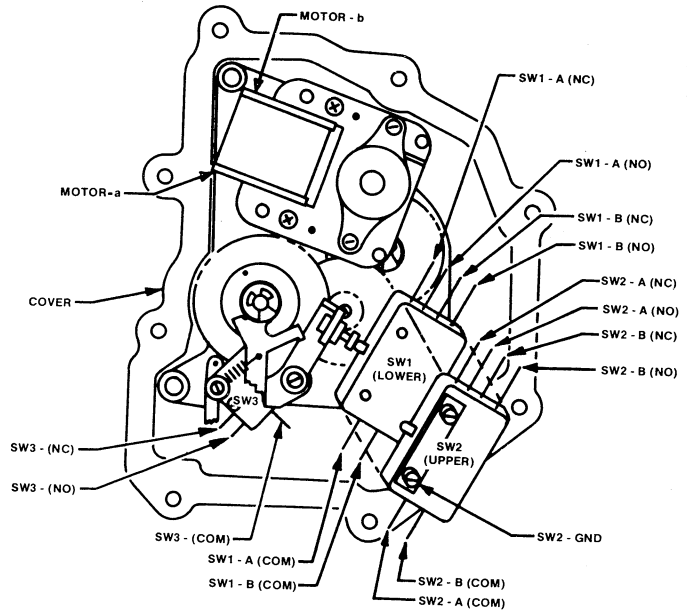

Figure 5. Series 7680 Internal Switch Adjustment.

g. Once continuity is attained, continue to adjust the switch until the operating button is depressed as far as it will go. Tighten the two screws on the switch adjusting plate.

h. Remove the feeler gage. The switch adjustment is now correct.

### 3. Pump Motor Switch (S1) and Solenoid Control Switch (S2) Replacement and Adjustment for Series 7680 (see Figure 2).

Note: Always adjust S1 first.

- Remove all power to the electric reset.
- Insert reset motor subassembly in cover, item 9, to stabilize the output drive assembly while adjusting switches.
- Connect an ohmmeter across terminals S1-B common and S1-B N.O. or S2-B common and S2-B N.O. (if installed).
- Rotate the mechanism by hand until pawl, item 5, rides upon the outside diameter of its cam.
- Loosen lock nut, Figure 5. Turn adjusting screw until continuity is registered on the ohmmeter.

**CAUTION: TO AVOID MISALIGNMENT, DO NOT LOOSEN THE TWO RETAINING SCREWS HOLDING THE SWITCHES TO THE PLATE.**

- Once continuity is attained, turn adjusting screw an additional 5/6 turn (approximately 0.028" linear movement).
- Tighten lock nut to 6 lb-in. while keeping the adjusting screw from rotating.
- Adjust second switch (if installed) as just described.

### 4. Reset Motor Switch (S3) Replacement, item 1, Figure 1:

- Disconnect the leads.
- Remove the mounting screws and washers.
- Install a new switch, making sure the blade actuator is above the clutch group cam on Series 7269.
- Secure the switch with the screws and washers. Reconnect the leads.

Note: While tightening the screws, use finger pressure to rotate the switch so that the blade actuator is toward the center shaft on Series 7269.

### C. CLUTCH GROUP REPLACEMENT – SERIES 7269 ELECTRIC RESET. Figure 1.

**WARNING: POWER MUST BE OFF WHEN WORKING ON THE UNIT. TO PREVENT PERSONAL INJURY, PROPERTY LOSS AND EQUIPMENT DAMAGE.**

- Remove the reset motor switch, item 1, the cam, item 4, and the pump motor switch, item 7.
- Rotate the switch pawl group, item 6, to the left and remove the clutch group retaining ring.
- Lift out and replace the clutch. Reverse procedure for installation.

### D. PUMP HANDLE STOP ADJUSTMENT – SERIES 7269 ELECTRIC RESET. Figure 6.

- Where possible, examine the reset cam to determine if the electric reset is a counterclockwise or clockwise model.

Note: Many pumps have permanent stops which are not adjustable.



2. When the pump handle is turned to the “motor on” position, the distance between the post in the cam slot and the end of the cam slot must be 1/8 inch minimum to 3/8 inch maximum. This is accomplished by gently turning the pump operating handle to the “on” position until it reaches the end of its travel. Back the handle off by approximately 1/2 inch and adjust the handle stop to this point. Check this position by returning the handle to the “off” position and again turn the pump on. If the pump starts, then the handle is adjusted correctly.

Note: The pump motor switch is factory adjusted to actuate at 3/8 inch in the “motor on” position.

3. Adjust the pump handle to the “motor off” position in the same manner. If the motor is off at this point, the adjustment is correct.

**CAUTION: TO PREVENT ELECTRIC RESET DAMAGE BE SURE THERE IS 1/8 INCH MINIMUM CLEARANCE BETWEEN THE POST AND ENDS OF THE CAM SLOT IN BOTH “MOTOR ON” AND “MOTOR OFF” POSITION.**

**E. EXTERNAL PUMP HANDLE STOP INSTALLATION – SERIES 7269 ELECTRIC RESET.** Figure 7.

External pump handle stops must be used to prevent damage to the internal stops of the electric reset. If external stops do not exist on the pump frame, they must be installed.

1. Install external stops on the pump frame so the cam does not reach the extreme limits of the internal stops.

Note: There are both clockwise and counterclockwise resets. Be sure to use the appropriate limit information in Figure 7.

**F. SERIES 7269 RESET COVER REPLACEMENT.** When installing the reset cover, be sure the slot in the center shaft mates with the cam tang. Install all bolts finger-tight. Turn the center shaft couplings to ensure proper engagement. Tighten the cover bolts.

**G. SERIES 7680 RESET COVER REPLACEMENT.** When installing the reset cover, be sure that both the operating handle and the internal parts are in the pump motor ON position (See Section II, Paragraph B). Failure to follow this procedure could result in output shaft binding.

**CAUTION: BEFORE UNIT IS APPROVED AND RETURNED TO NORMAL USE, PERFORM A COMPLETE VISUAL AND OPERATIONAL CHECK OF THE TOTAL SYSTEM TO PREVENT EQUIPMENT DAMAGE.**

**SECTION IV. PARTS**

See Parts List No. 231079 for Series 7269 Electric Reset.

See Parts List No. 251146 for Series 7627/7680 Electric Reset.

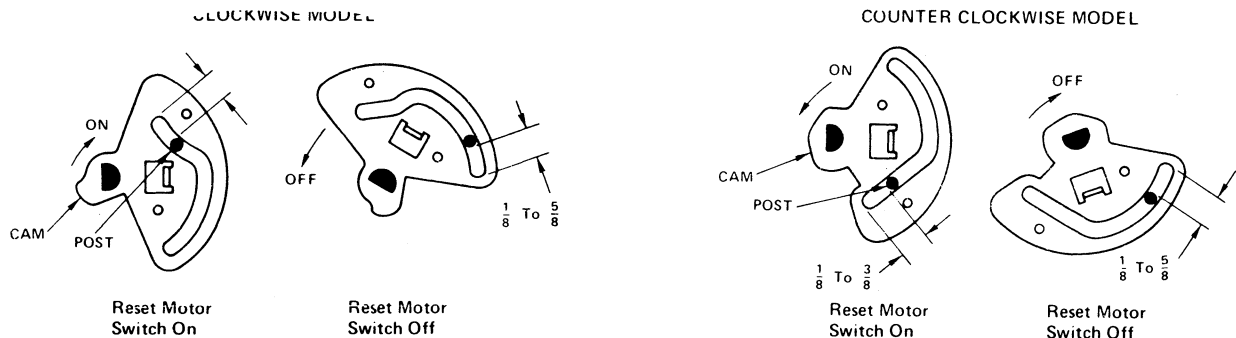

Figure 6. Pump Handle Stop Adjustment – Series 7269 only.

**H. TROUBLESHOOTING.**

TYPE OF FAILURE	POSSIBLE CAUSE	CORRECTION
Nothing happens when pump handle is turned on or off.	Lack of power to the pump, or product in the tank.	Check circuit breakers and/or fuses, as well as switches. Check tank for product.
Computer resets, pump motor does not run.	<p>Self-contained Pump:</p> <ol style="list-style-type: none"> <li>1. Faulty switch, item 7, Fig. 1.</li> <li>2. Faulty pump motor.</li> <li>3. Broken wire or connection to pump motor.</li> </ol> <p>Remote Pump:</p> <ol style="list-style-type: none"> <li>1. Faulty switch, item 7, (lower) Figure 1.</li> <li>2. Faulty auxiliary or solenoid switch, item 8 (upper).</li> <li>3. Upper pawl stuck, item 6.</li> </ol>	<p>Use ohmmeter for continuity check.</p> <p>Replace broken or malfunctioning parts.</p>



H. TROUBLESHOOTING – Continued

<p>Computer does not reset, pump motor does not operate.</p>	<p>With the cover off, check tang on item 4, on Series 7269. Be sure it is not broken and cam is attached securely to the shaft.</p> <p>Improper pump stop adjustment.</p> <p>Open circuit or defective reset motor switch, item 1.</p> <p>Broken tang between the electric reset package and the computer shaft cam.</p>	<p>If tang is broken, replace item 4, on Series 7269. Be sure that the pump handle stops are in proper relation to the electric reset stops. For this relationship, refer to paragraph D.</p> <p>With the cover off, rotate cam item 4, to “motor on” position, and with an ohmmeter check the continuity of the reset motor switch, item 1, across wired terminals. An open circuit would indicate a defective switch. Replace item 1.</p> <p>Replace cam.</p>
<p>Electric reset has cycled, computer does not reset, and pump motor runs.</p>	<p>Check all pins in drive train of computer.</p> <p>Possible broken or missing drive washer between computer and electric reset package.</p>	<p>Replace broken pin.</p> <p>Replace washer.</p>
<p>Pump motor operates continuously, cannot be turned off.</p>	<p>Defective pump motor switch, item 7.</p> <p>Possible pin sheared on electric reset cover coupling.</p> <p>Broken tang on cam, item 4, on Series 7269 or broken braze.</p> <p>Defective clutch mechanism, item 2, on Series 7269.</p> <p>Inspect leads for broken wires.</p>	<p>Replace switch, Paragraph B.</p> <p>Replace pin.</p> <p>Replace cam.</p> <p>Replace cam group.</p> <p>Replace wires.</p>
<p>Electric reset motor runs continuously in off position.</p>	<p>Defective switch, item 1.</p> <p>Defective clutch group.</p>	<p>Replace switch, Paragraph B.</p> <p>Replace clutch group, Paragraph C.</p>

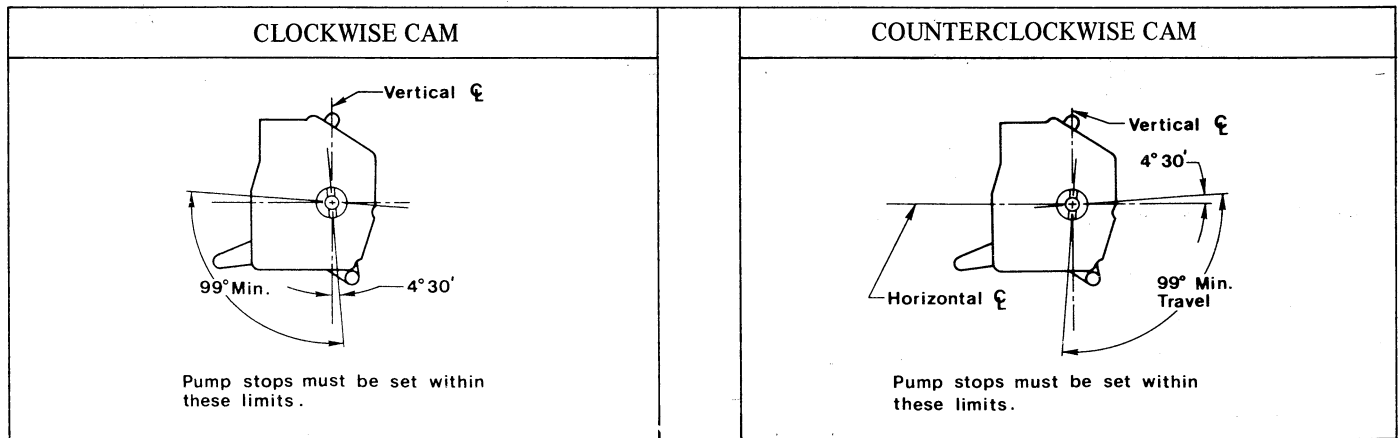

Figure 7. External Pump Handle Stops.





6th Avenue at Burns Crossing, P.O. Box 1673, Altoona, PA 16603-1673 Phone (814) 695-4476, or (800) 873-3313, Fax (814) 695-7605, or (800) 234-5350

BRAZIL: Sao Paulo • CANADA: Mississauga, Ontario • ENGLAND: Richmond Surrey • FRANCE: Aulnay-Sous-Bois • GERMANY: Aldingen • SINGAPORE: Singapore