

# bms

Group of companies



Process Automation



# bms

Group of companies

**FAFNIR™**

# Process Automation

Level Sensors | Level Detectors | Overfill Prevention

Sensors and Systems: [www.bms-ltd.com](http://www.bms-ltd.com)



Accuracy



Flexible



Reliable

# LS 300 and LS 500

## Protect Your Most Valuable Assets with the LS 300 and LS 500 Level Detection and Overfill Solution: Thermal Level Detector

With the FAFNIR thermal level detector (LS 300 with LS 500) with ATEX approval, your business and valuable liquid assets are protected. Our solution comprises a sensor, LS 300, which sits inside the tank and a transducer, LS 500, which manages the output relays. For polluting, corrosive and expensive liquids, the LS 300 with LS 500 certified as overfill prevention is an indispensable component for environmental and business protection.

### Why Choose LS 300 with LS 500?

#### Quick and Precise

- + Easy installation due to a 2-wire connection to the transducer, protected against reverse polarity
- + The level detector requires no maintenance after installation, no hidden costs
- + No on-site calibration required

#### Dependable

- + Full and empty alarms for containers, storage tanks, underground and above-ground tanks, IBCs, tank wagons, barrels, bottles and collecting vats
- + Proven: tens of thousands of installations across Europe
- + Self-testing sensors
- + The overfill prevention fulfills the requirements of the German Water Resources Act (WHG)
- + SIL 2 certified

#### Durable

- + With no moving parts, the LS 300 boasts excellent life expectancy and outstanding reliability
- + Space-saving, robust and corrosion-free design
- + Adaptable, flexible; with an intermediate flange which is only 3mm in diameter or with DN 200 flange, we have a solution for almost any application

#### Applications

- + Any tank type or size
- + Collecting vats
- + Pilot plants and prototype systems
- + Tank arms for filling



## LS 300 Sensor – Technical Data

Process temperature	Standard temperature: -25 °C ... +50 °C High temperature: -25 °C ... +80 °C Low temperature: -40 °C ... +50 °C (pressure-free)
Process pressure	0 bar ... 25 bar
Immersion switch delay	< 2 s
Heating-up time	At -20 °C < 2 min., At +60 °C < 15 s
Probe tube	
Wetted parts	Stainless steel 1.4571 (316Ti); Hastelloy C4/C22; Titan



LS 500 (wall housing)



LS 500 H Duo

## LS 500 Transducer – Technical Data

Name	LS 500	LS 500 H	LS 500 H Duo
Number of connections	1 Level detector	1 Level detector	2 Level detector
Auxiliary power	230 V <sub>AC</sub> ; 115 V <sub>AC</sub> ; 24 V <sub>DC</sub> ; 24 V <sub>AC</sub>	24 V <sub>DC</sub>	24 V <sub>DC</sub>
Power input	Max. 5 W	Max. 5 W	Max. 10 W
Ambient temperature	-25 °C ... +50 °C	-25 °C ... +50 °C	-25 °C ... +50 °C
Protection class	IP40		
Dimensions	H 150 x W 75 x D 110 [mm]	H 114.5 x W 22.5 x D 99 [mm]	H 114.5 x W 22.5 x D 99 [mm]
Outputs	Potential-free changeover contact: AC: U ≤ 250 V, I ≤ 5 A, P ≤ 100 VA DC: U ≤ 250 V, I ≤ 5 A, P ≤ 100 W	Potential-free changeover contact: AC: U ≤ 250 V, I ≤ 5 A, P ≤ 100 VA DC: U ≤ 250 V, I ≤ 5 A, P ≤ 100 W	Potential-free changeover contact: AC: U ≤ 250 V, I ≤ 5 A, P ≤ 100 VA DC: U ≤ 250 V, I ≤ 5 A, P ≤ 100 W
Output 1	Response to level detector 1	Response to level detector 1	Response to level detector 1
Output 2	Function S (interference) Optional: Option Z (Level detector 1 response)	Function S (interference) Optional: Option Z (Level detector 1 response)	Level detector 2 response
Options	Approval for LPG	SIL 2*	

\* no second output, available in 1th quarter 2017

## Versions

Our LS 300 Standard sensor is suitable for most process connections, with variable screw-in unit or welded flange. For mobile applications with plug, for very critical applications also with pneumatic test connection, to test the sensor not only electronically, but the real physical measurement principal. For vehicles, tank containers and tanks which are moved frequently, we also offer our level detector with a plug. This allows a quick coupling and decoupling of the level detector.

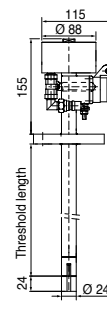
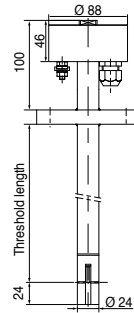
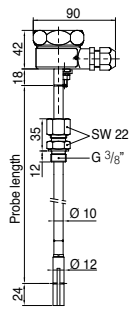

Name	LS 300 Standard	LS 300 FSU	LS 300 FSPU-Steck
Connection housing	Brass chrome-plated	Stainless steel	Stainless steel
Cable terminal	Cable gland	Cable gland	DD28 Connector
Probe tube	10 mm / protective sleeve 12 mm	24 mm	24 mm
Minimum process connection			
Tube fitting	G 3/8"	G 1"	G 1"
Flange	DN 15	DN 25	DN 25



## Steck and Duo Versions

For all applications where you need more than one level detector for your process control or as a warning in addition to the overflow protection. For vehicles, tank containers, and tanks which are moved frequently, we also offer our level detector with a plug. This allows a quick coupling and decoupling of the level detector.

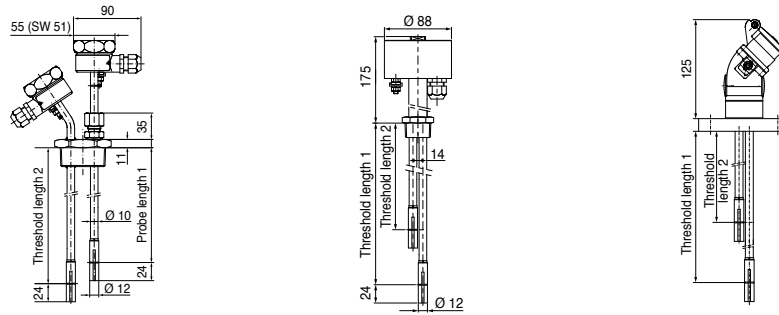

Name	LS 300 EU Duo	LS 300 ESU Duo	LS 300 FU Duo Steck
Connection housing	Brass chrome-plated	Stainless steel	Stainless steel
Cable terminal	Cable gland	Cable gland	DD28 connector
Probe tube	2 x 10 mm / protective sleeve 12 mm	2 x 10 mm / protective sleeve 12 mm	2 x 10 mm
<b>Minimum process connection</b>			
Tube fitting	R 1"	R 1"	R 1"
Flange	DN 25	DN 25	DN 25

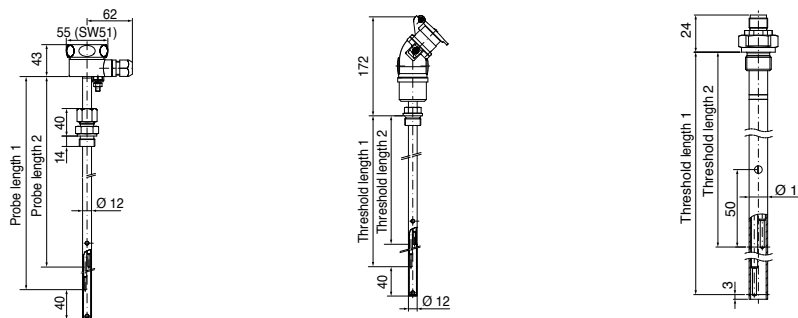

Name	LS 300 E Duo	LS 300 EXU Steck Duo	LS 300 Ex Steck (Mono/Duo)
Connection housing	Brass chrome-plated		
Cable terminal	Cable gland	DD28 connector	M12 connector
Probe tube	12 mm	12 mm	12 mm
<b>Minimum process connection</b>			
Tube fitting	G 1/2" (variable)	G 3/4"	G 3/8"

## Special Design

We offer a variety of special designs that are designed where space is limited or installation conditions are difficult and challenging. Here are some examples from our portfolio of special designs – challenge us!

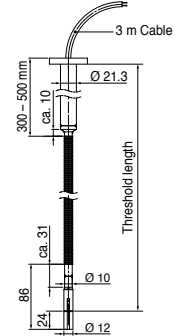
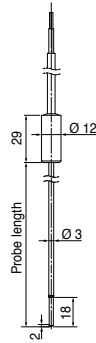
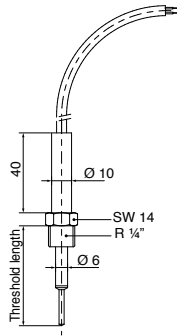

Name	LS 300 E B6	LS 300 B3	LS 300 FUX
Connection housing			
Cable terminal	Cable is moulded and fixed	Cable is moulded and fixed	Cable is moulded and fixed
Probe tube	6 mm	3 mm	10 mm / socket 12 mm
Minimum process connection			
Tube fitting	R 1/4"		

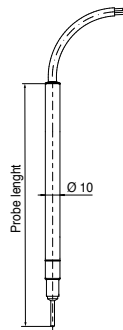
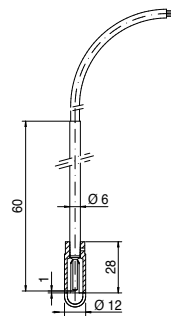
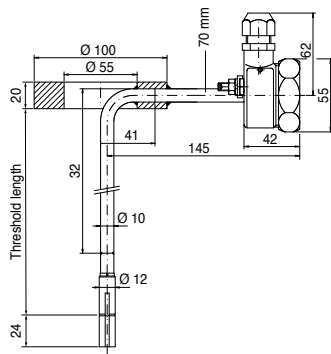

Name	LS 300 Intermediate Flange	LS 300 Interstitial	LS 300
Connection housing	Brass chrome-plated		
Cable terminal	Cable gland	Cable is moulded and fixed	Cable is moulded and fixed
Probe tube	10 mm / sleeve 12 mm	6 mm / 12 mm	10 mm
Minimum process connection			
Flange	DN 50		



BMS Group | Bulk Meter Services Ltd  
3 Faversham Road, Challock, Ashford, Kent, TN25 4BQ

Phone: 0345 230 7887  
Email: [sales@bms-ltd.com](mailto:sales@bms-ltd.com)

[www.bms-ltd.com](http://www.bms-ltd.com)

**Sensors & Systems Worldwide: [www.bms-ltd.com](http://www.bms-ltd.com)**